

产品信息 Product Information

Q602-A

项目/Project		参数
轴数/Degree of the freedom		6
运行半径/Working radius		700MM
最大负载/Maximum load		5KG
额定负载/Rated load		3KG
工作范围 Working range	轴1/Axis1	-175°~+175°
	轴2/Axis2	-130°~+50°
	轴3/Axis3	-120°~+50°
	轴4/Axis4	-175°~+175°
	轴5/Axis5	-120°~+120°
	轴6/Axis6	-180°~+180°
重复定位精准度 Position repeatability		±0.05MM
机身材质 fuselage material		6061铝合金 6061 Aluminum alloy
本体重量/Body weight		25KG
输入电压/Input voltage		220V
动力装置/Power plant		交流伺服电机 AC Servo Motor
减速装置/Reduction gear		谐波减速 Harmonic deceleration
环境要求 Environmental requirements	温度/Temperature	5°C-50°C
	湿度/Humidity	10%-80%
安装方式/Installation		台面、侧装、倒装 Table top, side mount, flip mount
最大速度 Maximum speed	轴1/Axis1	176°/SEC
	轴2/Axis2	176°/SEC
	轴3/Axis3	148°/SEC
	轴4/Axis4	237°/SEC
	轴5/Axis5	237°/SEC
	轴6/Axis6	400°/SEC

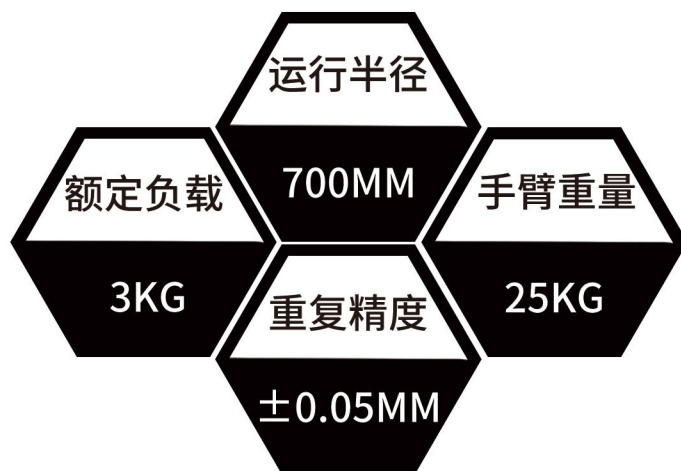

产品运行范围图 Range diagram

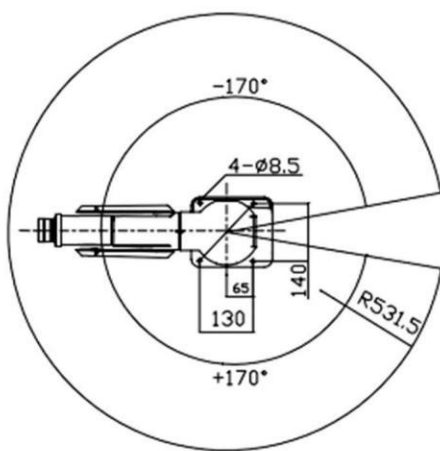
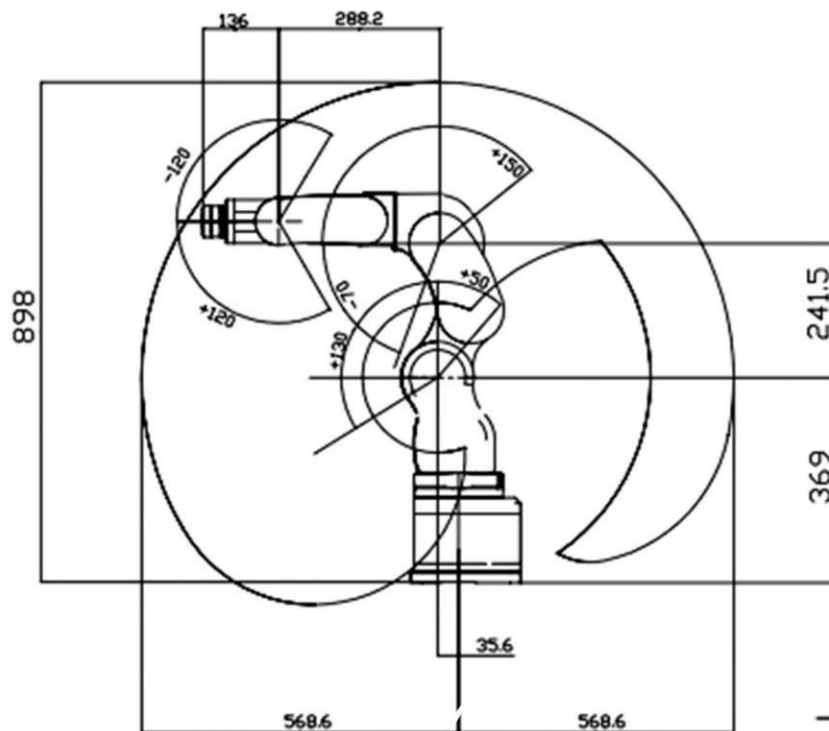

法兰图 Flange drawing

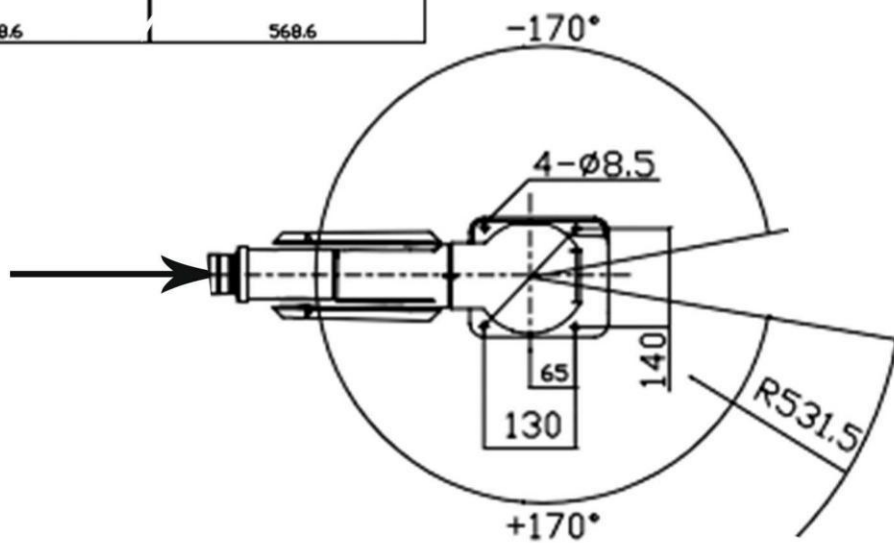

底座安装图 Base installation drawing

