

## product information

Project		parameter
Degree of the freedom		6
Working radius		700MM
Maximum load		3KG
Rated load		2KG
Working range	J1	-175°~+175°
	J2	-130°~+50°
	J3	-120°~+50°
	J4	-175°~+175°
	J5	-120°~+120°
	J6	-180°~+180°
Position repeatability		±0.05MM
Maximum speed for terminal axis		500MM/S
Body weight		23KG
Input voltage		220V
Total power		360W
Noise level		< 80dB
Environmental requirements	Temperature	5°C-40°C
	Humidity	10%-80%
Installation		Table top, side mount, flip mount
Fuselage material	6061 Aluminum alloy	
Power plant	Integrated servo motor contains multi-turn absolute encoders (4 pcs); Integrated servo motor with brake including multi-turn absolute encoder (2 pcs)	
Reduction gear	Harmonic deceleration (1-6 axis)	
Back to zero position	Multi-turn absolute encoder	

## G602-A--1200×1000×720-1



**Hardware composition:** workbench, robotic arm body, handling and palletizing module, trajectory module, polishing module, and conveying module.

**Software platform:** teach pendant, robot host computer

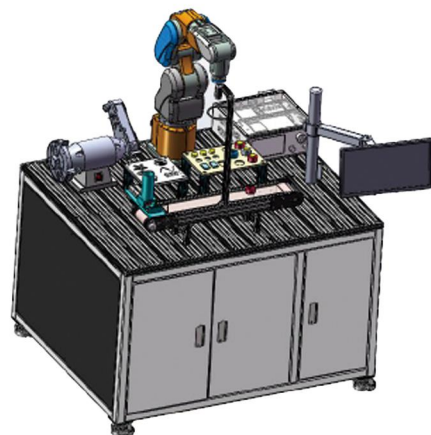

Workbench size: 1200×1000×720

# Range Diagram

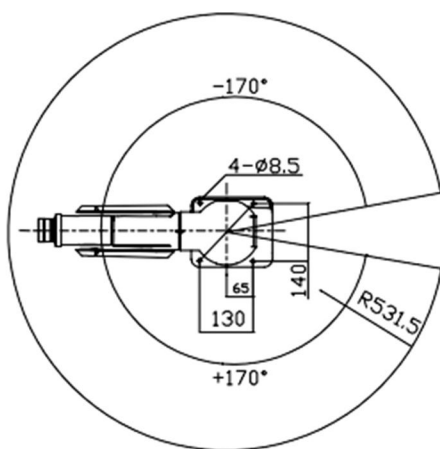
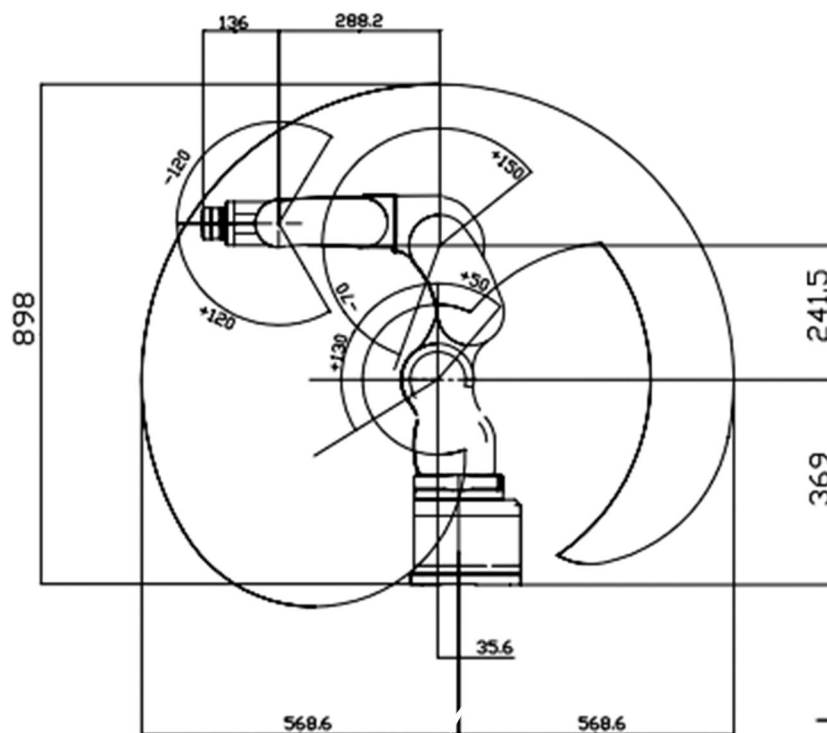

Flange drawing

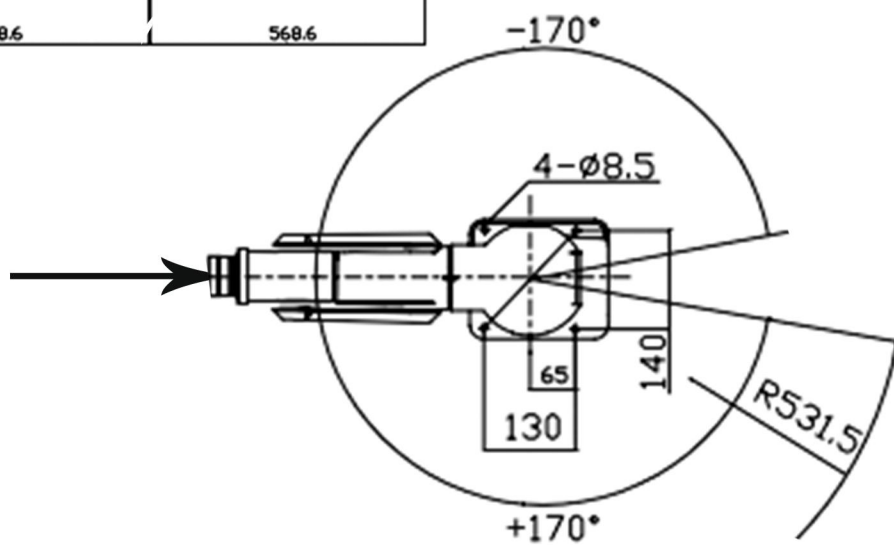

Base installation drawing

